

TECHNICAL SPECIFICATION

Main pump capacity	: 18 bar / 4m ³ /h / 4 kW.
Washing pump	: 2 bar / 4m ³ /h / 4 kW.
Electric immersion heater	: 9 kW.
Extraction	: 2,0 m ³ / min / 800 Pa / 0,55 kW.
Turbine rotation figure	: 3000 rotations.
Blast medium capacity	: 60 - 100 Kg / min.
Turbine motor	: 5,5 kW.
Blast chamber ØxL	: 700 x 700 mm.
Max. load	: 150 kg.
Blast chamber volume	: 100 Litres.
Blast duration	: 1 - 30 min.
Wash duration	: 1 - 30 min.
Drying duration	: 1 - 3 min.
Water temperature	: 0 - 70° C.
Tank capacity	: 225 Litres.

ACCESSORIES

- Rinsing module.
- Extraction equipment.
- Automatic emptying pump equipment.
- Alkaline soap dosing system.
- Automatic blast medium dosing system.
- Weekly timer.
- Oil trap.
- Turbine frequency converter.
- Electric console in stainless steel.
- Special wearing parts for the turbine.

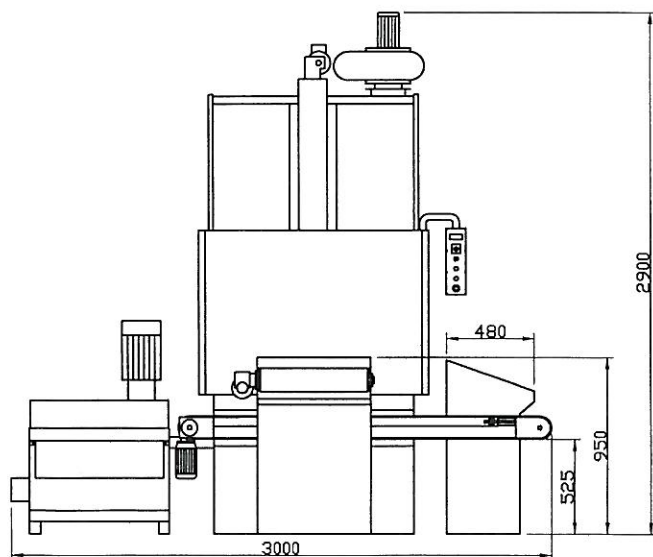

APPLICATIONS



Springs

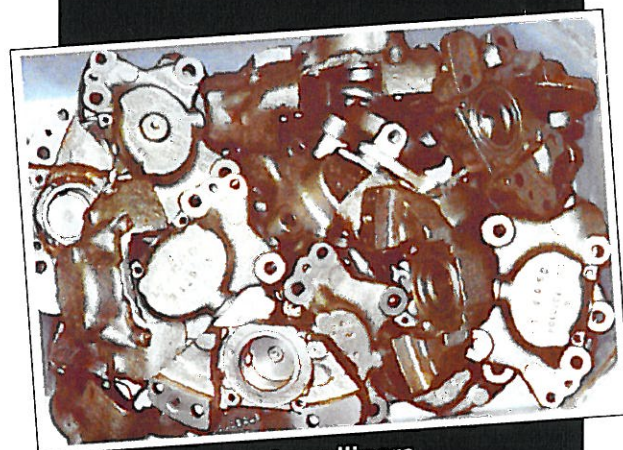

Brake callipers



Static motor parts

- European and International Patents Pending.

Vapormatt Ltd reserve the right to change without notice any of the specifications included in this brochure. The content is for illustration only and does not constitute an offer for sale.

© Vapormatt Ltd. 2001.

Doc. ref : NM-131-B PPP - (12/01)



Vapormatt
 SURFACE FINISHING
 Equipment and Abrasives
Vapormatt Limited
 Rue a Chiens-St. Sampson's
 Guemsey-British Channel Islands
 Telephone Int.+44 (0)1481 253195
 Facsimile Int.+44 (0)1481 252369

Hydratec Systems Limited
 Monarch Centre • Venture Way
 Priorswood Industrial Estate
 Taunton • Somerset TA2 8DE • UK
 Telephone 01823 257976
 Facsimile 01823 336446

Vapormatt Incorporated
 5936 Keystone Drive • Bath
 Pennsylvania 18014 • USA
 Telephone Int. +1 610 837 7277
 Facsimile Int. +1 610 837 4006